

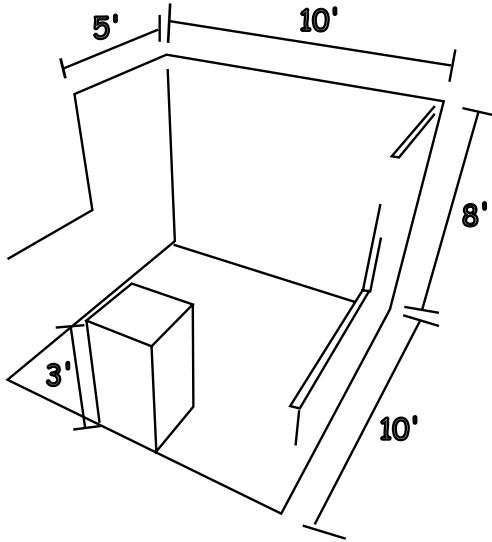

CMAA Club Business Expo Booth Type Description



A. 10' x 10' Exhibit Spaces – Aisle Booths (Linear/In-Line) and Corner Booths (Two-Aisle Exposure)

Booth spaces with a minimum of one adjacent neighbor may not exceed eight feet in height in the rear half (five feet) of the booth. The front five feet of the booth space may not exceed three feet in height. Please refer to the drawing for clarification. No merchandise may be hung or suspended in the front half of the booth. Rigging is not permitted.

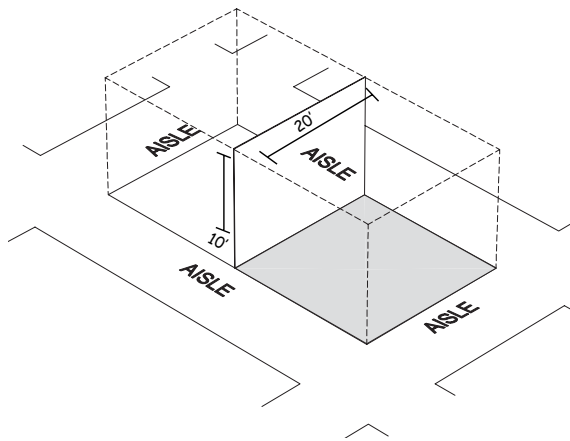

B. Split Island Booths (Three-Aisle Exposure)

A Split Island Booth is two or more 10' x 10' spaces with three-aisle exposure which shares a common back wall with another Split Island booth. The exhibitor may make full use of the space up to the maximum allowable height of 10 feet within the back half of the booth space. However, back draping will be set at eight feet in height. Displays placed to the front half of the space may not exceed three feet in height. Please refer to the drawing for clarification. No merchandise may be hung or suspended in the front half of the booth. Rigging is not permitted.

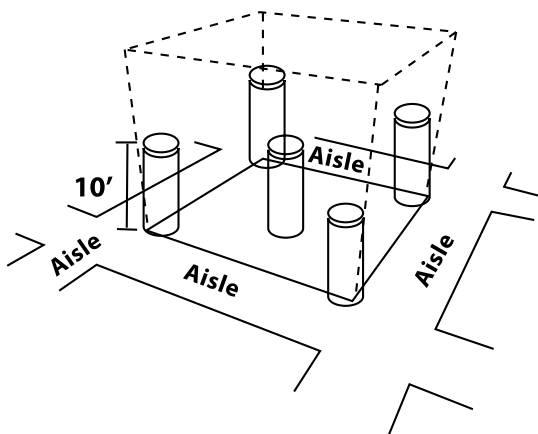

C. Island Booths (Designated island spaces include 20' x 20', and larger spaces that do not have other adjoining booth spaces)

Designated island booths may make full use of the floor space within the assigned space limitations. However, spaces must be constructed so that the view through the designated island is not blocked, and all equipment that is placed in the space exceeding the 10 foot height regulation must be approved in writing by CMAA prior to the show. Rigging is permitted with prior written approval by CMAA.