

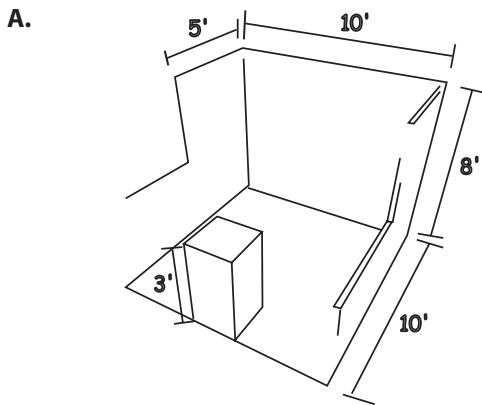

# CMAA 2025 Club Business Expo Booth Type Explanation

## Rules and Regulations Addendum A



**A. 10' x 10' Exhibit Spaces – Aisle Booths (Linear/In-Line) and Corner Booths (Two-Aisle Exposure)**

Booth spaces with a minimum of one adjacent neighbor may not exceed eight feet in height in the rear half (five feet) of the booth. The front five feet of the booth space may not exceed three feet in height. Please refer to the drawing for clarification. No merchandise may be hung or suspended in the front half of the booth. Sharing of space regardless of ownership is prohibited. Rigging is not permitted.

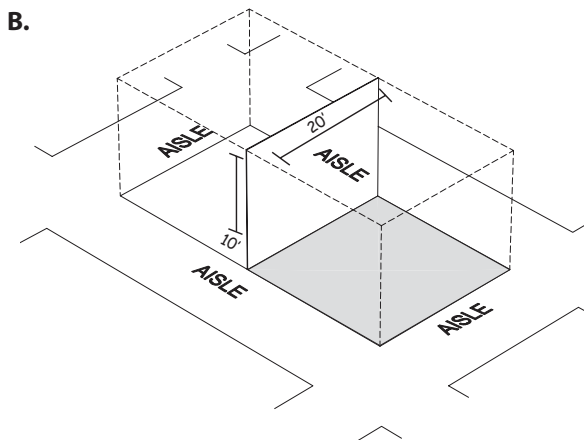

**B. Split Island Booths (Three-Aisle Exposure)**

A Split Island Booth is two or more 10' x 10' spaces with three-aisle exposure and shares a common back wall with another Split Island booth. Exhibitors may make full use of the space up to the maximum allowable height of 10 feet within the back half of the booth space. However, back draping will be set at eight feet in height. Displays placed to the front half of the space may not exceed three feet in height. Please refer to the drawing for clarification. No merchandise may be hung or suspended in the front half of the booth. Sharing of space regardless of ownership is prohibited. Rigging is not permitted.

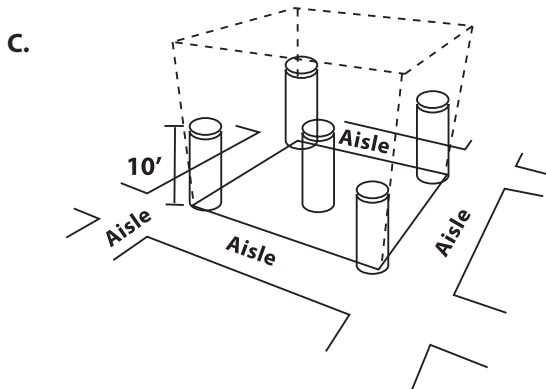

**C. Island Booths (Designated Island spaces do not have other adjoining booth spaces)**

Designated island booths are a minimum of 400 sq. ft. (20x20) – maximum 1,000 sq. ft. (20x50) and may make full use of the floor space within the assigned space limitations. The contracted company is the title company of the space. Spaces must be constructed so that the view through the designated island is not blocked, and all equipment that is placed in the space exceeding the 10-foot height regulation must be approved in writing by CMAA prior to booth set up.

Each company within the Island must show ownership by the title company. Companies showing within the space will not have individual identification on the floor plan or in the Directory. Each company within the Island (not including the titled company) must represent a minimum of 100 sq. ft. space. If additional companies are added to the Island, the Island must be enlarged in increments of 10x20.

Rigging is permitted with written approval by CMAA.

**D. Pavilion**

Pavilion space is available at the Club Business Expo. Please contact CMAA for details regarding this option. 703-739-9500